



MARUYAMA[®]

INTERNATIONAL PRODUCT CATALOG



LEGENDARY
JAPANESE
QUALITY

VISIT MARUYAMA-US.COM

OR SCAN THE
CODE FOR MORE:





MASANOBU OGASHIRA
Chairman

TAKAHARU UCHIYAMA
President

**LEGENDARY
JAPANESE
QUALITY
SINCE 1895**

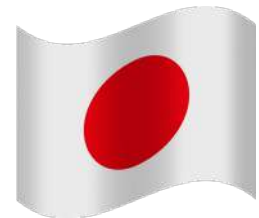

Since 1895, **Maruyama** has specialized in the manufacture of extreme-duty, commercial grade power equipment and sprayers for the agricultural, landscape and grounds maintenance industry. Our equipment is engineered and manufactured for the most demanding professionals who bet their bottom dollar on their working tools and settle for no less than the very best. This is what **Maruyama** offers. Extraordinary!

TABLE OF CONTENTS

Adjustable Throttle Features	3	Hover Mower	23
Heavy Duty Gear Box Features	4	Backpack Misters and Dusters.....	24
Feature Icon Descriptions	4	Manual Duster, Spreader and Soil Injector	25
Engine Features	5	Ultra Low Volume Fogger Attachment.....	25
Brush-Cutters	6	Piston Pumps	26
Edgers.....	10	Spray Piston Pump Engine Combos	28
Auger and Water Pump.....	11	High Capacity Skid Sprayer Units	29
Hedge Trimmers	12	BSM Tractor Boom Sprayer	30
Chainsaws.....	14	SSD Air Blast Sprayer	31
Multi-Cutters.....	16	Piston Pump 5-Cylinder.....	31
Blowers	18	BSA Hi-Clearance Boom Sprayer	32
Portable Power Sprayers	20	Accessories.....	34
Backpack Battery Sprayers.....	22	Model Specifications.....	36





**MORE
POWER
FOR THE PROS!**

NEW HIGH PERFORMANCE 2-CYCLE ENGINE

- Engine model FE360
- Displacement 35.5cc
- 78mm clutch for increased power transfer
- Low fuel consumption 450 g/Kw per hour
- Lightweight and powerful



HEAVY DUTY GEAR BOX FEATURES

1. REINFORCED ALUMINUM ALLOY GEARBOX

Thick structural sealed gearbox housing excellent for heavy duty bladed usage

2. 4-BEARING SUPPORT

Low vibration and able to absorb higher shock loads

3. HELICAL CUT CHROME MOLY PINION GEARS

Extremely durable materials for long time performance and corrosion resistance

4. HEAVY DUTY BLADE SHAFT

Designed to better absorb shock when utilizing metal blades

5. HEAVY DUTY PRESSED GLIDING PLATE

Cone shape to protect blade nut and protect gearbox shaft

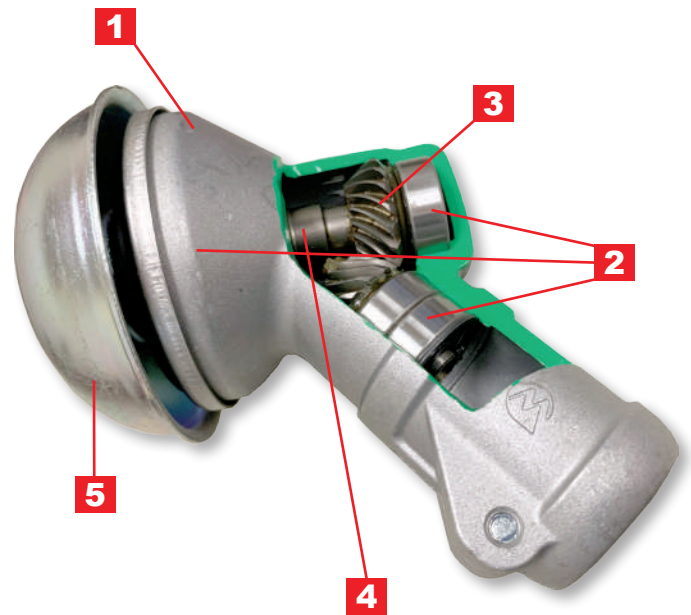

FEATURE ICON DESCRIPTIONS



DISPLACEMENT (CC)

Engine displacement refers to the total volumetric engine size measured in Cubic Centimeters, or "CC's", i.e. "42cc"



DRY WEIGHT (KG)

The weight of a complete unit without oil, gasoline, water, or chemical mix. The dry weight is measured after all components to operate the unit have been installed.



FUEL TANK (L)

The fuel tank is a container to safely store fuel supply until precisely metered into the engine through the carburetor.



EASY START

Refers to an assisted starter recoil system, developed by Maruyama, that significantly decreases the physical effort required to pull start the engine.



REVERSE START

The REVERSE2 START system incorporates fast and easy starts, without the drawbacks of added weight, expense and complicated components. Reverse Start: only requires one-quarter of the effort to start engine.



HARDENED STEEL

Every Maruyama hedge trimmer features induction hardened steel blades with dual-reciprocating movement for maximum sheering force.



ADJUSTABLE THROTTLE

Adjustable maximum throttle control for consistently regulating operational cutting speed.

- Waterproof kill switch button
- Cold-start feature that helps the engine start in colder weather and high altitude

CER ENGINE FEATURES

Maruyama CER Engines are powerful and friendly with the environment. Maruyama utilizes the latest clean 2-cycle engine technology that not only meets but exceeds today's strict emission regulations around the world. Their environmental friendliness and power will exceed your expectations. Get to know Maruyama technology.

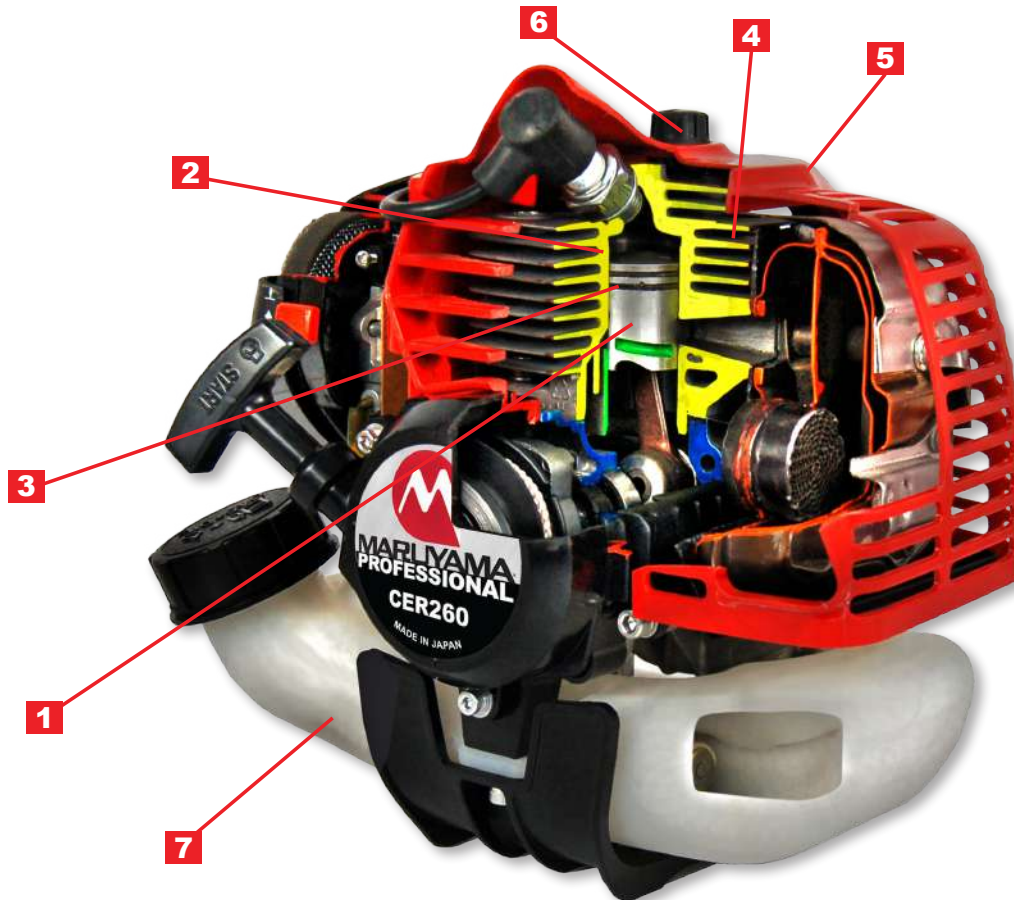

1. GROOVED PISTON

The re-circulatory groove is key to the patented HERE (High Efficiency Recirculating Engine) low emission system

2. HARD CHROME PLATED CYLINDER

Increases the life to the cylinder and improves performance

3. DUAL PISTON RINGS

Increased engine compression which translates into high torque and balance for power and performance

4. EXTENDED COOLING FINS

Improved cooling system for extended commercial usage

5. ELECTRONIC IGNITION SYSTEM

CDI ignition coil allows for a superior performance

6. QUICK RELEASE ENGINE COVER

One bolt design to remove cover makes service faster and easier

7. LARGE TRANSLUCENT FUEL TANK

Longer running time between fill-ups translate into increase profits for the commercial landscaper





Maruyama Trimmers and Brush-Cutters

are unique for what they do and how they do it. They are a rugged, dependable, day in and day out machine. Maruyama designs tools for good old-fashioned, roll up your sleeves, professional-grade use.

HEAVY DUTY BRUSH-CUTTERS





B420H

 41.5cc / AE420
 7.5kg
 1 L
 #366135





B43

 41.5cc / NE420
 7.9kg
 1 L
 #366082



B43R



 41.5cc / NE420
 8.0kg
 1 L
 #366122



**MORE
POWER
FOR THE PROS!**





B50R

 49.9cc / NE500
 8.3kg
 1 L
 #366124



BCV5020

 49.9cc / NE500
 8.9kg
 1 L
 #718557



* Trimmer head, blade or any cutting accessory is NOT included with brush-cutters

 Displacement (cc)
  Dry Weight (kg)
  Fuel Tank (L)
  Easy Start
  Reverse Start
  Hardened Steel
  Adjustable Throttle



HEAVY DUTY BRUSH-CUTTER

B420H FEATURES

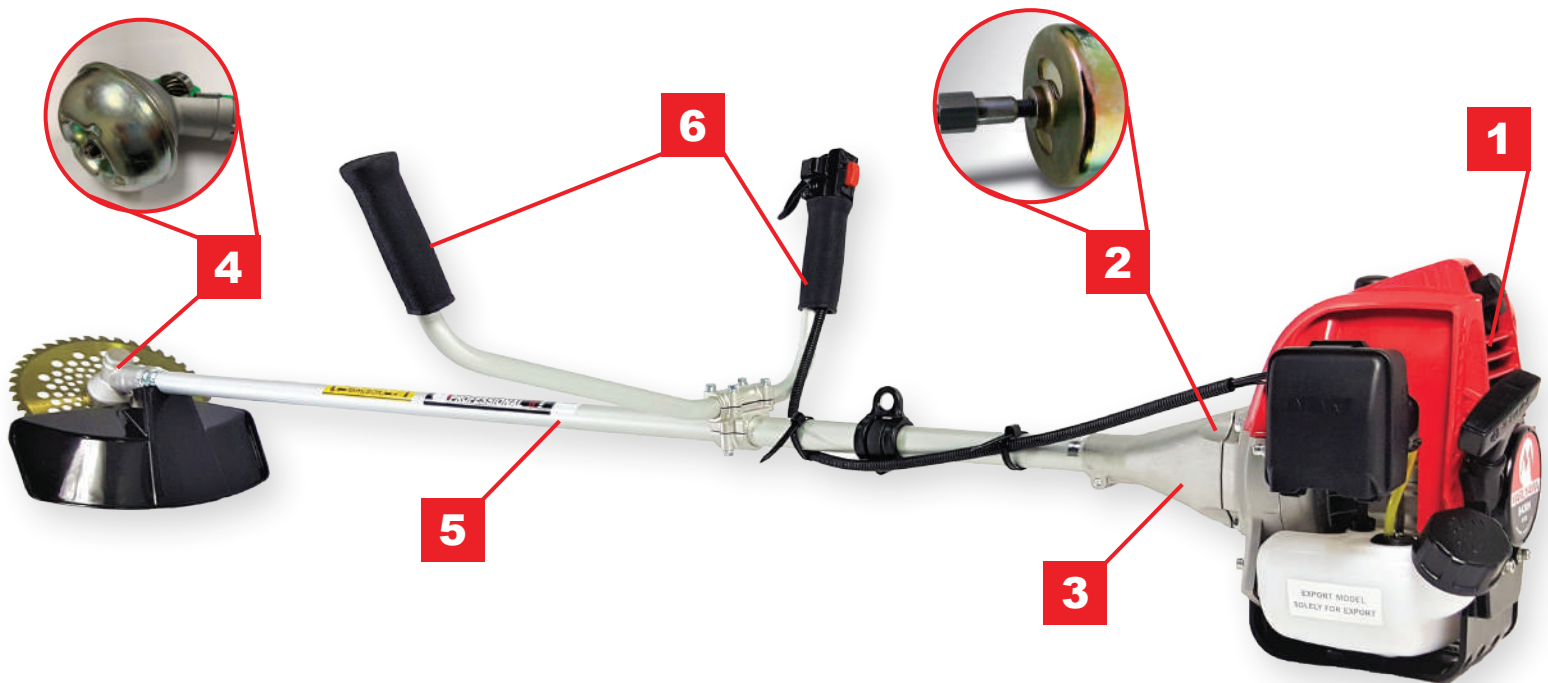

1. HEAVY DUTY 2-CYCLE ENGINE

Maruyama 2-cycle engines feature electronic ignition and Walbro carburetors for easy start. Dual piston rings and chrome impregnated cylinder manufactured for heavy duty continuous applications.

2. THREADED CLUTCH SHAFT

The solid inner drive-shaft is threaded to the clutch drum, which eliminates vibration and improves durability.

3. DUAL ANTI-VIBRATION CLUTCH HOUSING

Proven system that manages to reduce engine and shaft vibration for increased operator comfort.

4. 4-BEARING HEAVY DUTY GEAR CASE

Chrome moly helical cut gears are supported by 4 high-speed ball bearings in a sealed gear case. This design produces low vibration and absorbs high-shock loads.

5. SOLID POLISH STEEL SHAFT

Designed for greater load capacity, maximum torque, minimum vibration and extreme durability.

6. OFF SET HANDLE GRIP

Bull horn handle with rubber grip offers superior comfort and excellent balance for the end user.



SWIVEL SHAFT BRUSH-CUTTERS



BC360HE

35.5cc / FE360
 7.2kg
 1 L
 #366153

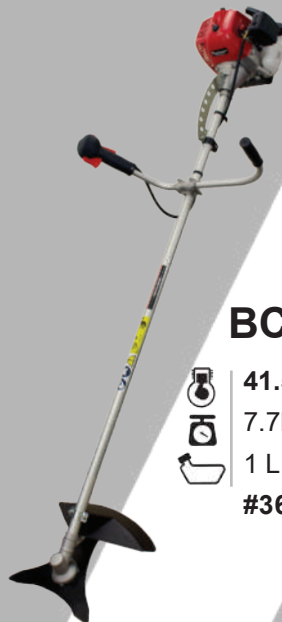

BC420HE

41.5cc / AE420
 7.7kg
 1 L
 #366154



BF420H

41.5cc / AE420
 7.7kg
 1 L
 #366155



BF43R

41.5cc / NE420
 8.1kg
 1.0 L
 #366123

MORE POWER FOR THE PROS!



THREADED CLUTCH SHAFT

The solid steel inner drive-shaft is threaded at the clutch end, which eliminates vibration

ERGONOMIC DESIGN SWIVEL HANDLE GRIP

Our ergonomic-design handle grip offers superior comfort and excellent balance for the user.



HIGH TORQUE ENGINE

Engineered with high compression ratio resulting in higher torque and power. CARB / EPA compliant.

EASY START

The easy start system has incorporated the best features of an electric starter, fast and easy starters.



DUAL ANTI-VIBRATION

Helps reduce operator fatigue and provides a more comfortable working experience.

* Trimmer head, blade or any cutting accessory is NOT included with brush-cutters



LIGHT WEIGHT BRUSH-CUTTERS



BC2259H

22.5cc / AE230
 4.5kg
 0.6 L
#366081



BC329H

31.8cc / AE320
 6.0kg
 1 L
#347494



BC360H

35.5cc / FE360
 7.0kg
 0.8 L
#366142

* Trimmer head, blade or any cutting accessory is NOT included with brush-cutters

COMPACT AND POWERFUL LOOP HANDLE TRIMMERS



BC230

22.5cc / AE230
 4.0kg
 0.6 L
#366152



B270L TURBO

25.4cc / CER260
 5.5kg
 0.6 L
#364851



GEAR
REDUCTION
RATIO = 1.9 : 1



B300L TURBO

30.1cc / CER300
 5.5kg
 0.6 L
#364854



GEAR
REDUCTION
RATIO = 1.9 : 1



B420L

41.5cc / CER420
 7.8kg
 1.0 L
#364857



* Trimmer head, blade or any cutting accessory is NOT included with brush-cutters

BACKPACK PROFESSIONAL BRUSH-CUTTERS

MOBILITY. COMFORT. PERFORMANCE.

Maruyama backpack brush-cutters are designed to make the job easier. Ideal for cutting brush on difficult narrow hilly terrains, overgrown slopes, coffee plantations, vineyards and orchards.

MBS360
 31.8cc / AE320
 9.6kg
 1 L
#366162



* Trimmer head, blade or any cutting accessory is NOT included with brush-cutters

Displacement (cc)
 Dry Weight (kg)
 Fuel Tank (L)
 Easy Start
 Reverse Start
 Hardened Steel
 Adjustable Throttle

EDGERS - CURVED AND STRAIGHT SHAFT



ADJUSTABLE BLADE HEIGHT

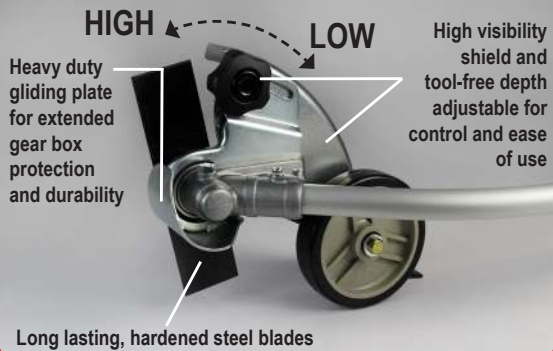

- Professional 2-cycle engines
- New adjustable throttle



E270

- 24.5cc / CER260
- 6.0kg
- 0.6 L
- #364861**
-



E300S

- 30.1cc / CER300
- 6.35kg
- 0.6 L
- #364862**
- * STRAIGHT SHAFT
-



WATER/TRANSFER PUMP



Utilized throughout the world in the toughest applications (including agriculture, construction and emergency flood relief) Maruyama water pump is designed to stand up to commercial challenges. Awesome power, rugged durability and Maruyama's long experience in pump technology have come together to create an extraordinary series of extreme-duty water pumps.

MIP2524

- 22.5cc / EE200
- 4.5kg
- 0.45 L
- #332328**

Flow rate..... 120 L/min
 Dynamic head 38 Meter
 Intake suction port.....25mm



- Quick-connect fitting included
- Compact and lightweight, yet professional grade with extreme durability

AUGER



Robust. Minimum Effort. Great Performance. Maruyama's superior quality, one-man power auger incorporates the latest in 2-cycle technology with its 3.5 HP engine that features a 1:45 dual stage gear ratio for maximum torque, but with minimum effort.

OPTIONAL AUGER BITS for MAG500:

- #229860 - Auger drill bit 90mm
- #229861 - Auger drill bit 150mm
- #234436 - Auger drill bit 200mm
- #234438 - Auger drill bit 250mm

MAG500

- 50cc / NE500
- 10.4kg
- 0.5 L
- #363578**
-



HEDGE TRIMMERS



**PRECISION
SHARPENED
BLADES**
on ALL 3 SIDES*

**FORWARD
FACING EXHAUST**
No brown spots on hedges
due to downward exhaust.



Solid. Dependable. Simply The Best.

The finest hedge trimmer available today. Great for sculpting, sheering or reaching high branches, these extraordinary hedge trimmers are engineered to balance power, durability and comfort under heavy, daily use. Every Maruyama hedge trimmer features induction hardened steel blades and dual reciprocating movement for maximum sheering force. Better yet, every Maruyama hedge trimmer features precision ground and polished cutting edges for the cleanest cuts and minimum leaf “browning”.

All Maruyama Hedge Trimmers use the state-of-the-art CER230 engine, which is lightweight and powerful. The CER engine family is unrivaled in power to weight performance as well as being a low emission, compliant engine which uses far less fuel than previous generation engines.



HEDGE TRIMMERS



H23F

- 22.5cc / CER230
- 5.6kg
- 76cm
- #362408**
-



H23FL

- 22.5cc / CER230
- 6.2kg
- 102cm
- #362409**
-



H23DF

- 22.5cc / CER230
- 5.9kg
- 61cm
- #362404**
-



H23DFL

- 22.5cc / CER230
- 5.85kg
- 76cm
- #362405**
-



H23DFR



5-POSITION
ROTATING
HANDLE

- 22.5cc / CER230
- 5.3kg
- 61cm
- #362406**
-



H23DFLR

- 22.5cc / CER230
- 5.85kg
- 76cm
- #362407**
-



BIG M

BH24G

- 22.5cc / CER230
- 4.5kg
- 61cm
- #362410**
-

* The blades on the BH24G are sharpened on 2 sides - not 3

EXTENDED HEDGE TRIMMER

EH230D

- 22.5cc / CER230
- 5.8kg
- 50.8cm
- #364863**
-

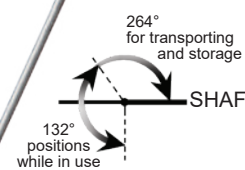

EH270D-S

- 25.4cc / CER260
- 6.0kg
- 50.8cm
- #364865**
-

EH230DSL

- 22.5cc / CER230
- 6.3kg
- 61cm
- #364864**
-

D = Double, F = Forward Exhaust, L = Long Blade, R = Rotating Handle

Displacement (cc) Dry Weight (kg) Fuel Tank (L) Easy Start Reverse Start Hardened Steel Adjustable Throttle 1-Side 2-Sides



PROFESSIONAL CHAINSAWS and PRUNERS



PRE-VENT SYSTEM

Debris and sawdust are dispersed leaving only clean air running through the carburetor



EASY START

Easy Start System incorporates the best features of an electric starter for fast and easy starters



ANTI-VIBRATION

Double protection for the operator



Compact. Balance. Extreme duty.

Maruyama's chainsaws are ideal for professional landscapers and tree-care specialists. They are ideal for cutting firewood, clearing land, and forestry. Great for cleaning up after natural disasters.



- Proven Japanese 2-cycle engine technology
- Automatic priming and chain lubrication
- Transistorized electronic starting system
- Inertia activated chain brake
- Chromed steel connecting rods
- Walbro carburetor
- High performance centrifugal clutch
- Chromed cylinders
- Fuel mix ratio 50:1



PROFESSIONAL CHAINSAWS



TOP
HANDLE

MCV31T-14

- 30.1cc / CER300
- 3.5kg
- 35.6cm / 14in.
- Chain/pitch: 91PX / 3/8in.
- #362797** (Bar and chain included)



REAR
HANDLE

MCV31R-14

- 30.1cc / CER300
- 3.3kg
- 35.6cm / 14in.
- Chain/pitch: 91PX / 3/8in.
- #362796** (Bar and chain included)



PROFESSIONAL PRUNERS

PS300 Pole Pruner

- 30.1cc / CER300
- 6.8kg
- 0.6 L
- 25.4cm / 10in.
- Chain/pitch: 91PX / 3/8in.
- #365011**
(Bar and chain included)



TPP270 Telescopic Pole Pruner

- 25.4cc / CER260
- 8.6kg
- 0.6 L
- 25.4cm / 10in.
- Chain/pitch: 91PX / 3/8in.
- #364866**
(Bar and chain included)



Maximum shaft reach from ground
WITH EXTENSION Approx. 5.5 Meters
 Shaft length without extension Approx. 2.5 Meters
 Shaft extension length 1.2 Meters



PROFESSIONAL CHAINSAW ACCESSORIES

PART NO.	DESCRIPTION	PART NO.	DESCRIPTION	PART NO.	DESCRIPTION
840481	Bar 10", 3/8" for PS30 and TPP27	840482	Chain 10", 3/8" for PS30 and TPP27	841029	RIM Sprocket 0.325, 7T
842460	Bar 12", 3/8" for MCV331T-12	842457	Chain 12", 3/8" for MCV331T-12	840483	RIM Sprocket 3/8", 7T
842461	Bar 14", 3/8" for MCV331R-14	842458	Chain 14", 3/8" for MCV331R-14		
286828	Bar 14", 0.325 for MCV31R and MCV31T	289538	Chain 14", 0.325 for MCV31R and MCV31T		
842467	Bar 18", 3/8" for MCV381	842463	Chain 18", 3/8" for MCV381		
840874	Bar 20", 3/8" for MCV51	841025	Chain 18", 3/8" for MCV51R		
844049	Bar 20", 3.25" for MCV51	840715	Chain 20", 3/8" for MCV51R		
		844050	Chain 20", 3.25" for MCV51		



QUICK CONNECT MULTI-CUTTERS



Versatility and productivity make the Maruyama Multi-Cutter System the finest professional grounds maintenance tool available. An extraordinary all-in-one product that adapts to almost any application, the multi-cutter transforms from trimmer to edger to hedge trimmer to pruner to cultivator and more.

Ideal as a low space, low investment back-up tool for the large landscape operation or the one and only tool for the smaller operation.

MULTI-CUTTERS BACKPACK and STRAIGHT SHAFT USES QC QUICK-CONNECT™ ATTACHMENTS



M420BK-QC

41.5cc / CER420
 10.4kg
 1.0 L
#364860



M270QC

25.4cc / CER260
 4.5kg
 0.6 L
#364858



M300QC

30.1cc / CER300
 4.5kg
 0.6 L
#364859

- PROFESSIONAL POWER – Gets the job done right
- One heavy-duty 2-cycle Maruyama engine for multiple QC attachments
- NEW ADJUSTABLE THROTTLE
- Hard chrome and polished cylinders for longer engine life
- Dual isolation anti-vibration makes work more comfortable

Displacement (cc)
 Dry Weight (kg)
 Fuel Tank (L)
 Easy Start
 Reverse Start
 Hardened Steel
 Adjustable Throttle



QUICK CONNECT™ MULTI-CUTTER ATTACHMENTS

- Heavy-duty gear-case
- 360° Counter-rotating blades
- 7mm solid steel driveshaft

Maruyama offers the only landscape blade that cuts in and around water areas, bunkers, sand traps and rock without launching objects everywhere.

QUICK CONNECT™

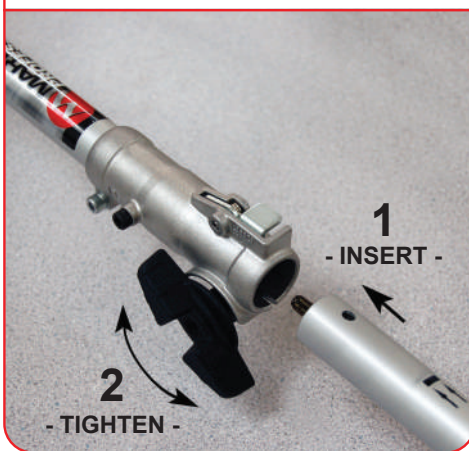

QC-LB
LANDSCAPE BLADE (V)
#391431



QC-S
TRIMMER
Ideal for trimming along fences, walls, around flower beds and everyday landscaping.
#364527



QC-ST TURBO
TRIMMER
Ideal for trimming along fences, walls, around flower beds and everyday landscaping. Featuring a powerful Turbo reduction gearbox 1.9 : 1
#364528



QC-HT
50cm
HEDGE TRIMMER
Perfect for shaping long and wide hedges. 60-0cm blade, fix head
#364523



QC-HTS
40.6cm
HEDGE TRIMMER
Perfect for shaping long and wide hedges. 40.6cm Blade, 132° articulating head
#364533

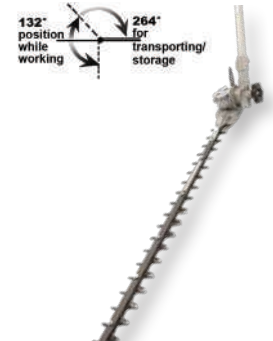

QC-HTR
60cm
HEDGE TRIMMER
Perfect for shaping long and wide hedges. 60.0cm blade, 270° articulating head
#364532



QC-PL
LONG PRUNER
Cuts high branches with ease, shaft length 150cm, 10 inch bar
#365014



QC-T
TILLER/CULTIVATOR
Ideal for turning flower bed soil and aerating
#364526



QC-ES
STRAIGHT EDGER
For that perfect manicure edge along the sidewalk, driveways and patios. Adjustable blade height
#364525



QC-E
EDGER
For that perfect manicure edge along the sidewalk, driveways and patios. Curve shaft, adjustable blade height
#364524

BLOWERS



**Powerful.
Productive.
Balanced Design.**

Maruyama blowers are designed to maximize productivity. To us that means high-performance over a long product life. Balancing sound, power and weight into machines that provide the best features, value, durability and performance season after season.



AIR CONDITIONED PADDING AND WIDE SHOULDER STRAPS



ADJUSTABLE THROTTLE PISTOL

HAND-HELD BLOWER



BL32



30.1cc / CER300

4.3kg

0.55 L

#395833



Sound rating70 dB(A)

AIR volume 12.9 m³/min

AIR velocity290 km/hr



ADJUSTABLE THROTTLE CONTROL



**OPTIONAL:
SHREDDER/
VACUUM
ATTACHMENT KIT
w/ heavy-duty steel
shredder blade (included)
#395747**



BACK PACK BLOWERS

BL9000-GT

79.2cc / CER800
 10.9kg
 2.1 L
#395880

Sound rating78 dB(A)
 AIR volume*28.3 m³/min
 AIR velocity*362 km/hr
 Throttle Type.....Pistol



NEW BL70-SP

60.9CC / CER600
 9.5kg
 2.1 L
#395885

Sound rating75 dB(A)
 AIR volume*25.6 m³/min
 AIR velocity*289 km/hr
 Throttle Type.....Pistol



BL9000-GT-HA

79.2cc / CER800
 10.9kg
 2.1 L
#395881

Sound rating 78 dB(A)
 AIR volume* 28.3 m³/min
 AIR velocity* 362 km/hr
 Throttle Type..... Hip Assist



NEW BL70-HA

60.9CC / CER600
 9.5kg
 2.1 L
#395884

Sound rating75 dB(A)
 AIR volume*25.6 m³/min
 AIR velocity*289 km/hr
 Throttle Type..... Hip Assist



OPTIONAL:
TORNADO TIP BL9000
 Increase air volume
#276352



OPTIONAL:
TORNADO TIP BL70
 Increase air volume
#131870



* Air volume and velocity data with optional tornado tip

PORTABLE SPRAYERS

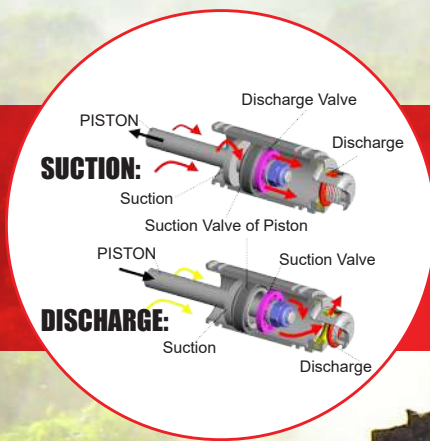

- Maruyama Patented Uniflow™ Technology
- Self-priming, self-lubricating and self-cooling Dual piston pump for increased pressure

MS076D
spraying
tomato fields



Excellent Control. Performance. Excellent Results.

Maruyama portable power sprayers offer the best performance and durability in its class. Maruyama's unique UNIFLOW positive displacement piston pump offers a consistent pressure providing supreme chemical coverage and penetration. The continuous improvement of our technology allows us to reach working pressures of up to 500 psi which allows us to effectively use a second lance and an endless number of specialized spray accessories. Ideal for the application of agrochemicals in agriculture, gardening, farms, greenhouses, open field crops, shrubs, fruit trees, vegetables and for pest control applications.



BACKPACK SPRAYERS



MS076D



2-CYCLE
25.4cc / EE260

7.8kg

#366563

Chem Tank 25 L

Flow Rate 7.5 L/min

PSI..... 500

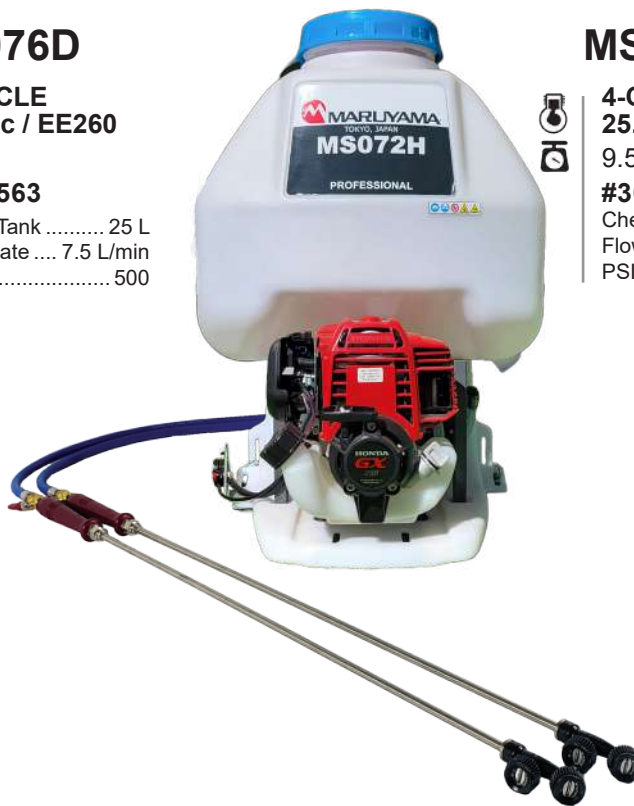

MS072 H



4-CYCLE
25.0 cc / GX25T

9.5 kg

#366515

Chem Tank 25 L

Flow Rate 7.1 L/min

PSI..... 435



MS0835



2-CYCLE
23.9cc / DE243

8.5kg

#544658

Chem Tank 25 L

Flow Rate 8.0 L/min

PSI..... 500



MS051



2-CYCLE
19.8cc / EE200

7.0kg

#366547

Chem Tank 25 L

Flow Rate 5.0 L/min

PSI..... 362



BACKPACK BATTERY SPRAYERS

Reliable. Lithium-Ion Battery.

Gets the job done.

Maruyama portable backpack sprayer is the ideal tool when performance matters. Equipped with a high-pressure pump, this small unit is more than capable of performing big jobs. Ideal for gardening, landscaping, green houses, pest control and many other applications that require a compact and powerful pump that can deliver up to 145 psi.



MS40Li

Tank capacity.....	15 L
Dry weight	5.3kg
Charging time	22 min
Flow rate.....	1.5 L/min
Lithium-ion battery.....	Makita 18V-3.0Ah BL1830
Part number.....	353080
Working time (3 settings).....	@ 43 psi - 300 min. @ 72 psi - 120 min. @ 145 psi - 45 min.

Nozzles included with MS40Li:

Black wide nozzle - **#117958** (shown)

Metal adjustable nozzle - **#127460**



HOVER MOWER



Introducing the **MHM480 Hover Mower**, featuring a compact design and powerful 79.2cc 2-cycle engine, giving you the ability to cut even the most difficult terrains at any angle.

Ideal for the following applications:

- Steep slopes
- Hard-to-trim uneven areas, such as bunkers, embankments, sand traps, and landscaping privacy mounds
- Marshes
- Water lines and wet, grassy areas

OPTIONAL KITS



STRAIGHT BAR BLADE KIT



HANDLE EXTENTION KIT



TRANSPORT WHEEL KIT



HEIGHT KIT

NEW

MHM480

79.2 cc / CER800

17.2 kg.

2.1 L



845995



Desplazamiento (cc) Peso en Seco (lb) Tanque de Combustible (oz) Tamaño de Barra

BACKPACK MISTERS and DUSTERS



Versatility. Accuracy. Control.

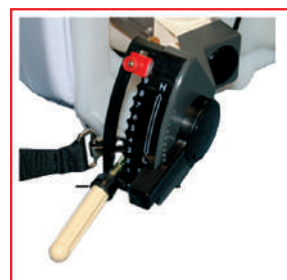

Ideal for a variety of applications, from crop cultivation to pest control, Maruyama Mist blowers can do it all. Our high performing backpack misters and dusters quickly deliver liquids and granules over a wide area. Low pressure air movement gives uniform chemical distribution in hard to reach places.



- **DUSTER CONTROL HIP LEVER**
27 different control settings for the exact required range needed for chemical powders and granular dusting applications
- **TOP QUALITY, NO-RUST PARTS**
allow for chlorine and caustic chemical applications without the risk of damaging the unit





MM92-V

-  **79.2cc / CER800**
-  **11.9 kg**
-  **2.0 L**
- Chem tank ...20.0 L**
- Flow Rate0-3.8 L/min**
- Max reach ... (H) 16m / (V) 13m**
- #352863**



MD8026

-  **64.7cc / TK65**
-  **12.5kg**
-  **2.0 L**
- Chem tank ..26.0 L**
- Discharge**
- Rate 0-8.0 kg/min**
- Max reach ..(H) 14m / (V) 10m**
- #352798**

 Displacement (cc)
  Dry Weight (kg)
  Fuel Tank (L)
  Easy Start
  Reverse Start
  Hardened Steel
  Adjustable Throttle



MANUAL DUSTER, SPREADER and SOIL INJECTOR

Specialized tools for everyday jobs that required a reliable application.



MG10
MANUAL SPREADER

Tank capacity	11.3 L
Approx weight	1.6kg
Volume of granules	0-2.3 L/min
Part Number	338119



MG51
MANUAL DUSTER

Tank capacity	4.5 L
Approx weight	2.8kg
Volume of dust	0-0.42 L/min
Part Number	338129



MI-3A
SOIL INJECTOR

Tank capacity	3.0 L
Approx weight	2.8kg
Chemical discharged	1-5ml
Lance depth (cm)	16-19-22-25
Part Number	325116

ULTRA LOW VOLUME (ULV) FOGGER ATTACHMENT



ULV Fogger Nozzle Attachment
Produces 39-64 micron droplets
#092667



ULV Fogger for MM30
Produces sub -25 micron droplets
#841068

OPTIONAL ACCESSORIES FOR MISTERS and DUSTERS



#121194 (for duster)
Rigid "Granule Blow Pipe"
discharges larger granular
chem. up to 20m



#100415 (for duster)
Rigid "Dusting T-Blow Pipe"
allows a single operator to
dust rows



#028700 (for duster)
"Granular Shower Blow Pipe"
discharges smaller chemical
up to 30m



#019888 (for duster)
"Dusting Blow Hose" provides
wide, uniform dust coverage
up to 30m



26-Liter tank for liquids (for MD8026)
#107298

SPRAYER PISTON PUMPS



MSD41 3/4
DIRECT DRIVE



MSD41 5/8
DIRECT DRIVE



MSD51 3/4
DIRECT DRIVE

Experience. Performance. Unmatched.

Unmatched experience in sprayer technology and design, our industrial-grade sprayers are engineered to provide optimal performance in agricultural, nursery, lawn and grounds maintenance and pest control applications. Over the last 125 years, we've built and tested our commercial sprayers to provide maximum power, superior quality and lasting durability. The results are extraordinary.

UNIFLOW™ PISTON PUMPS PATENTED, LEGENDARY QUALITY

- Maruyama piston pump technology utilizes our patented UNIFLOW™ design to ensure fluids move in one direction throughout the pump, without changing its direction
- Reduced pulsation and vibration
- Self-lubricating, self-priming and free from oil or grease contaminants
- Premium materials like stainless steel cylinders, chrome-moly crankshafts, oversized ball bearings, and die cast aluminum crankcases provide performance, strength and tolerance control

DIRECT DRIVE PUMPS

SPACE SAVERS. RELIABLE. EASY TO MAINTAIN.

	MSD41 3/4	MSD41 5/8	MSD51 3/4
Cylinders	3	3	3
Cylinder coating	CHROME	CHROME	CHROME
Direct drive type	GASOLINE	ELECTRIC	GASOLINE
Dry weight	5.6kg	5.6kg	7.8kg
Pressure (psi max.)	570	570	570
Suction volume (L/min @ 3600RPM)	30 L/min	30 L/min	40 L/min
Maximum RPM	3600	3600	3600
Required power (approx)	3.6 HP	3.6 HP	6.5 HP
Part number	366537	366538	366559



BELT DRIVEN CHROMED PISTON PUMP

RELIABLE. EASY TO MAINTAIN.



MS157



MS905



MS1505

Cylinders	2	3	3
Cylinder coating	CHROME	CHROME	CHROME
Direct drive type	BELT	BELT	BELT
Dry weight	6.4kg	40kg	41kg
Pressure (psi max.)	500	650	425
Suction volume (L/min @ 3600RPM)	9.9 L/min	90.5 L/min	150 L/min
Maximum RPM	1000	800	700
Required power (approx)	2.8 HP	8-13 HP	8-13 HP
Part number	324213	354170	354171

BELT DRIVEN CERAMIC PISTON PUMP

CHEMICAL AND HEAT RESISTANT



MS333



MS417



MS657



MS757

Cylinders	3	3	3	3
Cylinder coating	CERAMIC	CERAMIC	CERAMIC	CERAMIC
Drive type	BELT	BELT	BELT	BELT
Dry weight	7.2kg	11.5kg	21.7kg	23.8kg
Pressure (psi max.)	500	700	700	700
Suction volume (L/min @ 3600RPM)	23.2 L/min	30 L/min	56 L/min	60 L/min
Maximum RPM	1050	1000	1000	950
Required power (approx)	2.6 HP	3.5 HP	6.0 HP	7 HP
Part number	366572	354230	354233	354234

SPRAY PISTON PUMP ENGINE COMBOS



Versatile as a power sprayer, simple as a re-power kit.

Assembled from components matched for compatibility and superior quality, Maruyama spray piston pump engine combos are unrivaled for performance and extraordinary durability.

PUMP/ENGINE COMBOS

PATENTED UNIFLOW PISTON PUMPS + 4-CYCLE ENGINES



MS156EA



MSD41TECH



MSD41TEC-H



MS333ECH



MS417ECH

Pump	MS156	MSD41 3/4"	MSD41 3/4"	MS332	MS415
Drive type	BELT	DIRECT	DIRECT	BELT	BELT
Cylinder Coating	CHROME	CHROME	CHROME	CERAMIC	CERAMIC
Engine	Mitsubishi GB101LN	Honda GX160	Honda GX160	Honda GX160	Honda GX160
Spray Volume	13 L/min	30.3 L/min	30.3 L/min	24.0 L/min	30.0 L/min
Max Pressure	500 psi	570 psi	570 psi	500 psi	700 psi
Dry weight	6.9kg	30.0kg	32.5kg	36.0kg	40.0kg
Part Number	358489	366541	366545	358669	358668



Each pump combo includes suction hose, strainer assembly and bypass hose (with exception of MSD41TECH)



HIGH CAPACITY SKID SPRAYER UNITS



For long term performance, less down time and less maintenance, nothing beats a Maruyama High Capacity Skid Sprayer.

- Available in 50-gallon, 100-gallon and 200-gallon models
- Rugged aluminum frames
- Durable polyethylene tanks
- Optional low profile reel
- Complete line of optional guns, wands, nozzles and extensions

SKID SPRAYER UNITS



MSD41-50T



MSD41-50TE



MSD41-100T



MSD41-100TE

Frame	Aluminum	Aluminum	Aluminum	Aluminum
Pump	MSD41	MSD41	MSD41	MSD41
Engine	Honda GX160	Honda GX160	Honda GX160	Honda GX160
Chemical Tank	200 Liter	200 Liter	400 Liter	400 Liter
Spray Volume	23.2 L/min	23.2 L/min	23.2 L/min	23.2 L/min
Max Pressure	570 psi	570 psi	570 psi	570 psi
Hose Reel	MANUAL	ELECTRIC	MANUAL	ELECTRIC
Hose	100M, 10mm	100M, 10mm	100M, 10mm	100M, 10mm
Incl. Spray Accessory	MD9 Gun	MD9 Gun	MD9 Gun	MD9 Gun
Part Number	849302	849301	849304	849305



MSD41-100



MSD41-100E



MSD41-200



MSD41-200E

Frame	Aluminum	Aluminum	Metal	Metal
Pump	MSD41	MSD41	MSD41	MSD41
Engine	HONDA GX160	HONDA GX160	Honda GX160	Honda GX160
Chemical Tank	400 Liter	400 Liter	760 Liter	760 Liter
Spray Volume	23.2 L/min	23.2 L/min	23.2 L/min	23.2 L/min
Max Pressure	570 psi	570 psi	570 psi	570 psi
Hose Reel	MANUAL	ELECTRIC	MANUAL	ELECTRIC
Hose	100 Meter, 10mm	100 Meter, 10mm	100 Meter, 10mm	100 Meter, 10mm
Incl. Spray Accessory	MD9 Gun	MD9 Gun	MD9 Gun	MD9 Gun
Part Number	849308	849309	849306	849307



TRACTOR MOUNTED SPRAYERS



Maruyama's tractor sprayers are ideal for small and medium size farms. Ideal for sugar cane, berries, row produce growth in narrow rows and any kind of small tractor.*

- Extreme-duty Maruyama professional boom sprayer which mounts easily to tractor
- Maruyama's legendary triple piston pumps ensures durable, efficient service
- Adjustable 2-directional nozzles on the booms increase productivity and saves time due to not having to change out different types of nozzles in the field between sprays



**2-DIRECTION
YAMAHO NOZZLE**



**2-DIRECTION
ISO NOZZLE**



BSM201-3MX

BSM-301

BSM-500F-1

Applicable tractor	17 - 23 HP	+ 30 HP	+34 HP
Piston pump	MS331	MS331	MS655s
Flow rate	30 L/min	30 L/min	53 L/min
Max pressure	435 psi	435 psi	435 psi
Chemical tank capacity	200 Liter	300 Liter	500 Liter
Boom length	4.2 Meter	7.5 Meter	10.2 Meter
Nozzle type	14 nozzles (2-direction)	25 nozzles (2-direction)	34 nozzles (2-direction)
Nozzle type	ISO	Yamaha	Yamaha
Dry weight	115kg	125kg	200kg
Part number	328290	720032	328244

* Tractor not included



SSD600 TOW BEHIND AIR BLAST

Maruyama's SSD600 air blast sprayer is designed to economically meet the demands of specialty crop applications such as grapes, berries, cranberries, blueberries, fruit orchards, nut growers, nurseries, Christmas trees and papaya trees.

SSD600

Chemical tank	600 Liter
Chemical tank wash	80 Liter
Hand wash tank	16 Liter
Agitation	Hydraulic double jet
Pump	MS800
Pump speed	540 RPM
Pump pressure	215-290 psi
Flow rate	46 L/min
Turbine speed	2200 RPM
Air velocity	27-28 m/sec
Nozzle	14 nozzles (2-direction)
Part number	366906

REQUIRED POWER - 17-23 HP



BELT DRIVEN CHROME 5-PISTON PUMP

HIGH PRESSURE. CONSTANT PRESSURE. DEPENDABLE.

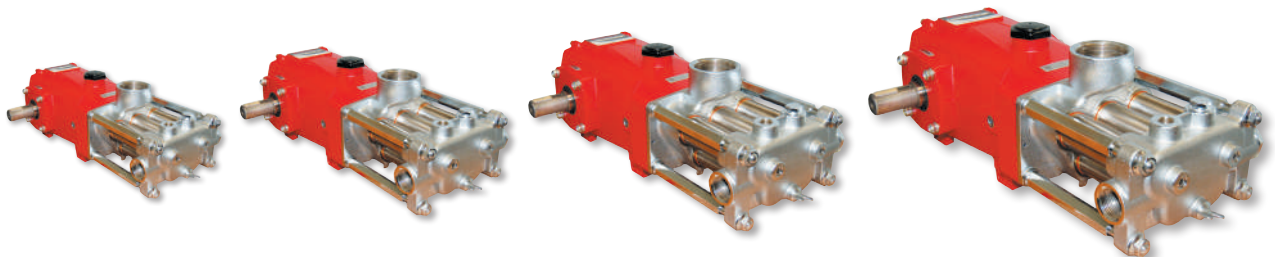

MS600F

MS1000F

MS1300F

MS1600F

	MS600F	MS1000F	MS1300F	MS1600F
Cylinders	5	5	5	5
Cylinder coating	CHROME	CHROME	CHROME	CHROME
Approx. weight	9.8kg	10.0kg	21.0kg	22.0kg
Pressure	726 psi	437 psi	580 psi	437 psi
Maximum RPM	1250	1250	1250	1250
Required net power (approx)	8.5 HP	8.5 HP	14.5 HP	14.5 HP
Suction volume	36 L/min	60 L/min	82 L/min	104 L/min
Irrigation @ rated RPM	36 L/min	60 L/min	82 L/min	104 L/min
Irrigation @ max. RPM	60 L/min	100 L/min	128 L/min	160 L/min
Crankshaft diameter	20mm	25mm	25mm	30mm
Max suction flow @ 540RPM	25.4 L/min	41.6 L/min	65.0 L/min	82.2 L/min
Max suction flow @ 1250RPM	60 L/min	100 L/min	128 L/min	160 L/min
Part number	354067	354068	354069	354070



BSA HIGH CLEARANCE BOOM SPRAYER

Cutting-edge innovation are the words that come to mind when describing Maruyama's large-scale sprayers. Incorporating the latest in sprayer technology and our expertise in UNIFLOW piston pumps, Maruyama has an extensive range of high clearance boom sprayers, tractor mounted sprayer and stereo sprayers. Ideal for orchard and crop spraying, broad acre spraying or any job specific large-scale spraying.

“CROP KING” High Clearance BSA-500 series

Ride-On Boom Tractor Sprayers

- 4 WD Transmission and 4 WS Steering
- High clearance sprayer from 81cm up to 110cm
- Will work on wet or dry terrain
- Narrow tires minimize crop damage



	BSA500 - 1500	BSA500 - 1800	BSA500 - 2000
Clearance height	81cm	81cm	81cm
Distance between tires	150cm	180cm	200cm
Chemical tank capacity	545 L	545 L	545 L
Boom length	7.8 Meter	7.8 Meter	7.8 Meter
Boom spray height	33 to 153cm	33 to 153cm	33 to 153cm
Nozzle type	26 nozzles(2-direction)	26 nozzles (2-direction)	26 nozzles (2-direction)
Piston pump	MS620	MS620	MS620
Flow rate	60 L/min	60 L/min	60 L/min
Engine	Kubota D722 (Diesel)	Kubota D722 (Diesel)	Kubota D722 (Diesel)
Engine output	10.7 ps @ 2300 RPM	10.7 ps @ 2300 RPM	10.7 ps @ 2300 RPM
Dry weight	800kg	820kg	840kg
Moving speed	0-10 km/hr.	0-10 km/hr.	0-10 km/hr.
Part number	720266	720419	720217



RIDE-ON BOOM TRACTOR SPRAYERS

“CROP KING” HIGH CLEARANCE



BSA500JMQ



BSA950.LM-1

BSA951CE



MINIMUM CROP DAMAGE

Narrow tires and high clearance greatly reduce crop damage



EFFECTIVE SPRAYING AND SAVE TIME

Ideal for spraying and misting fertilizers, fungicides, herbicides, etc.



“CROP KING” TRACTOR

Shown with enclosed cabin

BSA500JMQ

BSA950.LM-1

BSA951CE

Clearance height	120cm	81cm	81cm
Distance between tires	180cm	180cm	180cm
Chemical tank capacity	545 L	950 L	950 L
Boom length	10.2 Meter	Telescopic 9.9 to 15.9 Meter	Telescopic 9.9 to 15.9 Meter
Boom spray height	33 to 153cm	33 to 153cm	33 to 153cm
Nozzle type	26 nozzles (2-direction)	53 nozzles (2-direction)	53 nozzles (2-direction)
Piston pump	MS620	MS1000	MS1000
Flow rate	60 L/min	100 L/min	100 L/min
Engine	Kubota D722 (Diesel)	Kubota D1105 (Diesel)	Kubota D1105 (Diesel)
Engine output	14.5 ps @ 2300 RPM	20.9 ps @ 2600 RPM	20.9 ps @ 2600 RPM
Dry weight	895kg	1170kg	1365kg
Moving speed	0-10 km/hr.	0-10 km/hr.	0-10 km/hr.
Part number	720238	720233	721208



BRUSH-CUTTER ACCESSORIES



Chaps
(37.5" Wrap-Around)
#845670



Forestry Combo Set Helmet
#420282



Hanging Strap Assy
#228086



Shoulder Strap Assy
#220533



Ear Plugs [100/Cs]
#845496



Safety Glasses (Smoke) [12/Cs]
#845493
Safety Glasses (Clear) [12/Cs]
#845492

PROFESSIONAL LUBRICANTS

FOR 2-CYCLE ENGINES



Blue Ultra-Shield (2.6oz) [24/Cs]
849860

Blue Ultra-Shield (6.4oz) [24/Cs]
849861

Blue Ultra-Shield (12.8oz) [12/Cs]
849862



Formula Sd (100ml) [24/Cs]
849870

Formula Sd 1 Liter [12/Cs]
849871

Formula Sd (55gal) [14/Cs]
849872

TRIMMER HEADS

PROFESSIONAL FIXED AND BUMP



Nylon Cutter (K) - Orange
#210798



Katana Akai
Fixed Line Head
#840337



Fixed Line Head 4"
#288424



M-Twist Easy Feed (4.5" Lh)
#463743

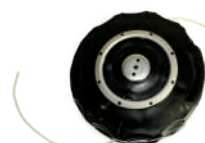

M-Twist Easy Feed (5.5" Lh)
#426930

PROFESSIONAL BLADES

AND TRIMMER LINE



Blade 2-Teeth, 9 Inch
#841385
Blade 2-Teeth, 10 Inch
#841388



Blade 3-Teeth, 9 Inch
#841381
Blade 3-Teeth, 10 Inch
#841380



Blade 4-Teeth, 9 Inch
#210179
Blade 4-Teeth, 10 Inch
#054751



Blade 8-Teeth, 10 Inch
#840895



Blade 26-Teeth, 10 Inch
#840956



Blade 40-Teeth, 9inch
#841384



SPRAY GUNS AND ATTACHMENTS

FOR SPOT AND SKID SPRAYERS



Top Gun
#832505



MD9 Gun
#842404

**MORE
POWER
FOR THE PROS!**



Wide 2-Head
Nozzle
#637074



Dual Head
Adjustable Nozzle
Tip 45 Iso
#639504



Soil Injector
#639258



Super Zoom
P-700
#417221



4-Nozzle Boom
#637153



Hi-Reach Gun
#417257

SPRAY GUNS AND ATTACHMENTS

FOR PORTABLE AND BACKPACK SPRAYERS



U2L Gun
#116126



Adjustable Nozzle
(45 Angle)
#588002



Mini Quick Nozzle
1.5mm.....#122038
1.3mm.....#425722
0.7mm.....#425721



Nozzle w/ Weed
Shield (Cr7)
#415077



Ring Type
5-Head Nozzle A
#74206



Wide Nozzle Ass'y
(Nn-D-5s)
#471938



Wide Nozzle Ass'y
(Nn-C-35s)
#814267



Adjustable Nozzle
#127460



2-Nozzle Wand,
Length 17cm
#417232



3-Nozzle Wand,
Length 27cm
#639508



Soil Injector
(R G1/4)
#637451



3-Nozzle Wand
length 58cm
#417233



4-Nozzle Wand
length 94cm
#417234



5-Nozzle Wand
length 127cm
#417235



5-Nozzle Wand
length 130cm
#639578



6-Nozzle Wand
length 130cm
#637117



4-Nozzle Boom
Driftless
#400475



Nozzle Pipe
90cm
#965062



Nozzle Pipe
120cm
#465064



Nozzle Pipe
150cm
#417208



Telescopic Nozzle Pipe
163-238cm
#465077

MODEL SPECIFICATIONS

TRIMMERS, BRUSH-CUTTERS and MULTI-CUTTERS

Model	Part Number	Engine Class	Displacement (cc)	Dry Weight (kg)	Easy Start	Blade Capable	Cutting Attachment	Carburetor Type	Carburetor Priming Pump	Fuel Tank (Liter)	Drive Shaft Type	Drive Shaft Diameter (mm)	Available Handle Type	Gear Reduction Ratio	Page
BC230	366152	LE230	22.5	4.0		✓	None	Diaphragm	✓	0.06	Solid	7	Loop	*1 : 1.36	9
BC2259H	366081	LE230	22.5	4.5		✓	None	Diaphragm	✓	0.06	Solid	7	Handle	*1 : 1.36	9
B270L TURBO	364851	CE260	25.4	5.5		✓	4.5 Semi	Diaphragm	✓	0.6	Solid	7	Loop	*1 : 1.9	9
M270QC	364858	CE260	25.4	4.5	✓	✓	None	Diaphragm	✓	0.6	Solid	7	Loop	*1 : 1.33	16
B300L TURBO	364854	CER300	30.1	5.5	✓	✓	4.5 Semi	Diaphragm	✓	0.6	Solid	7	Loop	*1 : 1.9	9
M300QC	364859	CER300	30.1	4.5	✓	✓	None	Diaphragm	✓	0.6	Solid	7	Loop	*1 : 1.33	16
BC329H	347494	AE320	31.8	6.0		✓	None	Diaphragm	✓	1	Solid	7	Handle	*1 : 1.33	9
MBS360	366162	AE320	31.8	9.6		✓	None	Diaphragm	✓	1	Flexible	7	Loop	*1 : 1.29	9
BC360H	366142	FE360	35.5	7.0		✓	None	Diaphragm	✓	0.8	Solid	8	Handle	*1 : 1.29	9
B420L	364857	CER420	41.5	7.8	✓	✓	4.5 Semi	Diaphragm	✓	1	Solid	8	Loop	*1 : 1.29	9
B420H	366135	AE420	41.5	7.5		✓	None	Diaphragm	✓	1	Solid	8	Handle	*1 : 1.29	6
B43	366082	NE420	41.5	7.9		✓	None	Diaphragm	✓	1	Solid	8	Handle	*1 : 1.29	6
B43R	366122	NE420	41.5	8.0	✓	✓	None	Diaphragm	✓	1	Solid	8	Handle	*1 : 1.29	6
BF43R	366123	NE420	41.5	8.1	✓	✓	None	Diaphragm	✓	1	Solid	8	Handle	*1 : 1.29	8
BF420H	366155	AE420	41.5	7.7		✓	None	Diaphragm	✓	1	Solid	8	Handle	*1 : 1.29	8
BC360HE	366153	FE360	35.5	7.2		✓	None	Diaphragm	✓	1	Solid	8	Handle	*1 : 1.235	8
BC420HE	366154	AE420	41.5	7.7		✓	None	Diaphragm	✓	1	Solid	8	Handle	*1 : 1.235	8
M420BK-QC	364860	CER420	41.5	10.4		✓	None	Diaphragm	✓	1	Flexible	7	Loop	*1 : 1.9	16
BCV5020	364164	NE500	49.9	8.9	✓	✓	3-T, 5" Semi	Diaphragm	✓	1	Solid	8	Handle	*1 : 1.29	6
BF50R	366125	NE500	49.9	8.4	✓	✓	None	Diaphragm	✓	1	Solid	8	Handle	*1 : 1.29	8
MBS360	366162	AE320	31.8	4.4	✓		None	Diaphragm	✓	1	Solid	7	Loop	*1 : 1.29	9

EDGERS

Model	Part Number	Engine Class	Displacement (cc)	Dry Weight (Kg)	Edger Blade Length	Regular Start	Cutting Attachment	Carburator Type	Priming Pump	Fuel Tank (L)	Drive Shaft Type	Diameter (mm)	Available Handle Type	Gear Reduction Ratio	Page
E270	364861	CER260	25.4	6.0	195mm	✓	2-T	Diaphragm	✓	0.6	Flexible	7	Loop	*1 : 1.33	10
E300S	364862	CER300	30.2	6.4	195mm	✓	2-T	Diaphragm	✓	0.6	Solid Shaft	7	Loop	*1 : 1.33	10

WATER PUMP

Model	Part Number	Engine Class	Displacement (cc)	Dry Weight (Kg)	Suction Volume (liter per minute)	Dynamic Head (meters)	Intake Port	Discharge Port	Fuel Tank (Liter)	Page
MIP2524	332328	EE220	22.5	4.5	120	38	25mm (1" X 1")	25mm (1" X 1")	0.500	11

AUGER

Model	Part Number	Engine Class	Displacement (cc)	Dry Weight (Kg)	Easy Start	Carburator Type	Priming Pump	Fuel Tank (Liter)	Available Auger Bits	Heavy Duty Air Cleaner	Available Handle Type	Gear Reduction Ratio	Auger Speed	Page
MAG500RS	363578	NE500	49.9	10.4	✓	Diaphragm	✓	1	50,75,100, 150, 200, 250 mm	✓	Loop	*25:1	195 rmp @8500 rpm	11



HEDGE TRIMMERS

Model	Part Number	Engine Class	Displacement (cc)	Dry Weight (Kg)	Cutter Type	Cutter Length	Cutter Pitch	Thickness	Throttle Control Lockout	Frontal Exhaust	Rotation Handle	Carburator Type	Priming Pump	Fuel Tank (Liter)	Gear Reduction Ratio	Sound Power Level Guaranteed dB(A)	Page
BH24G	362410	CER230	22.5	5.3	Double Sided	610 mm	35 mm	2.5 mm	√			Diaphragm	√	0.5	* 1 : 1.40	107	13
EH230D	364863	CER230	22.5	5.8	Double Sided	500 mm	35 mm	2.0 mm	√	√		Diaphragm	√	0.5	* 1 : 1.40	106	13
EH230DSL	364864	CER230	22.5	6.3	Double Sided	610 mm	35 mm	2.0 mm	√	√		Diaphragm	√	0.5	* 1 : 1.40	106	13
EH270D-S	364865	CER260	25.4	5.8	Double Sided	610 mm	35 mm	2.0 mm	√	√		Diaphragm	√	0.5	* 1 : 1.40	107	13
H23DF	362404	CER230	22.5	5.9	Double Sided	610 mm	35 mm	2.5 mm	√	√		Diaphragm	√	0.6	* 1 : 1.40	107	13
H23DFLR	362407	CER230	22.5	5.9	Double Sided	760 mm	35 mm	2.5 mm	√	√	√	Diaphragm	√	0.55	* 1 : 1.40	106	13
H23DFR	362406	CER230	22.5	6.3	Double Sided	760 mm	35 mm	2.5 mm	√	√		Diaphragm	√	0.55	* 1 : 1.40	106	13
H23DFL	362405	CER230	22.5	5.3	Double Sided	610 mm	35 mm	2.5 mm	√	√		Diaphragm	√	0.55	* 1 : 1.40	106	13
H23F	362408	CER230	22.5	5.6	Single Sided	760 mm	35 mm	2.5 mm	√	√		Diaphragm	√	0.5	* 1 : 1.40	107	13
H23FL	362409	CER230	22.5	5.3	Double Sided	610 mm	35 mm	2.5 mm	√	√	√	Diaphragm	√	0.55	* 1 : 1.40	106	13

CHAINSAWS

Model	Part Number	Engine Class	Displacement (cc)	Dry Weight (Kg)	Easy Start	Handle Type	Carburator Type	Priming Pump	Fuel Tank (Liter)	Max Output RPM	Bar Type	Bar Size	Chain Type	Pitch	Page
MCV31R-14	362796	CER300	30.1	3.5	√	Rear	Diaphragm	√	0.6	9500	Oregon®	12"	91PX	3/8"	15
MCV31T-14	362797	CER300	30.1	3.3	√	Top	Diaphragm	√	0.6	9500	Oregon®	12"	91PX	3/8"	15

CHAINSAW POLE AND TELESCOPIC

Model	Part Number	Engine Class	Displacement (cc)	Dry Weight (Kg)	Easy Start	Fix Length	Max Reach	Carburator	Priming Pump	Fuel Tank (Liter)	Lubrication System	Max Output RPM	Bar Type	Bar Size	Chain Type	Pitch	Page
PS300	849109	CER300	30.1	5.8	√	2.5 meter	4.25 meter	Diaphragm	√	0.6	√	9500	Oregon®	10"	91VXL	3/8"	15
TPP270	364866	CER260	25.4	8.6	√	4.25 meter	6.25 meter	Diaphragm	√	0.6	√	9500	Oregon®	10"	91VXL	3/8"	15

BLOWERS

Model	Part Number	Engine Class	Displacement (cc)	Dry Weight (Kg)	Type	Heavy Duty Air Cleaner	Anti-Vibration Device	Carburator Type	Priming Pump	Fuel Tank (Liter)	Air Volume	Page
BL32	395833	CER300	22.5	4.3	Handheld	√	√	Diaphragm	√	0.55	13 m3/min	18
BL70-SP	395885	CER600	60.9	9.5	Backpack	√	√	Diaphragm	√	2.1	25.6 m3/min	19
BL70-HA	395884	CER600	60.9	9.5	Backpack	√	√	Diaphragm	√	2.1	25.6 m3/min	19
BL9000 SP-GT	395880	CER800	79.2	10.9	Backpack	√	√	Diaphragm	√	2.1	28.3 m3/min	19
BL9000 HA-GT	395881	CER800	79.2	10.9	Backpack	√	√	Diaphragm	√	2.1	28.3 m3/min	19



BACKPACK POWER SPRAYERS

Model	Part Number	Engine Class	Displacement (cc)	Dry Weight (Kg)	Easy Start	Chemical Tank (Liter)	Lance	Nozzle	Carburator Type	Priming Pump	Fuel Tank (Liter)	Pump Type	Pressure Setting(psi)	Flow	Page
MS051	366547	EE200	19.8	7.0	✓	25	Single	Wide Double	Diaphragm	✓	0.6	Single Piston	362	5.0	21
MS076D	366563	EE260	25.4	7.8	✓	25	Double	Wide Double	Diaphragm	✓	0.6	Double Piston	500	7.5	21
MS0835	544658	DE243	23.9	8.6	✓	25	Single	Wide Double	Diaphragm	✓	0.6	Double Piston	500	8.0	21
MD072H	366515	6X25T	25	9.5	✓	25	Double	Wide Double	Diaphragm	✓	0.6	Double Piston	435	7.1	21

BATTERY BACKPACK POWER SPRAYERS

Model	Part Number	Chemical Tank (Liter)	Motor Class	Dry Weight (Kg)	Lance	Nozzle Included	Pressure Settings	Suction Volume	Running Time	Battery Pack	Charge Time	Special Feature	Page
MS40Li	353080	15	12V, 30W	5.3	Single	Wide double and adjustable cone	43 / 72 / 145 psi	1.5	45 / 120 / 300 min	Lithium-Ion 18-V	22 minutes	Flex Tank	22

BACKPACK MISTERS / DUSTERS

Model	Part Number	Engine Class	Displacement (cc)	Dry Weight (Kg)	Chemical Tank	Configuration	Throttle	Carburator Type	Carburator Priming Pump	Fuel Tank (Liter)	Regular Start	Liquid Flow Volume	Dust Flow Volume	Max Reach (Horizontal)	Page
MM92	352863	CER800	79.2	11.9	20	Mister	Frame	Diaphragm	✓	2.1	✓	0-3.8 lpm	--	14	24
MD8026	352798	TEX65	64.7	12.5	26	Duster	Frame	Diaphragm	✓	2.0	✓	--	0-8 K/min	11	24

PISTON PUMP

Model	Part Number	Suction Volume (liter per minute)	Maximum Pressure (psi)	Connecting Method	Dry Weight	Drive System (V-Pulley)	RPM	Min. Required (Hp)	Piston Material	Number of Piston	Power Drive	Length (mm)	Width (mm)	Height (mm)	Page
MS157	324213	10~13	500	V-belt	6.4	152 (A-2)	800~1000	1.2 Hp	Chrome	2	V-Belt	374	215	286	27
MS905	354170	90~100	650	V-belt	40.0	261 (B-3)	700~800	8-13 Hp	Ceramic	3	V-Belt	640	454	590	27
MS1505	354171	131~150	425	V-belt	41.0	261 (B-3)	700~800	8-13 Hp	Ceramic	3	V-Belt	691	454	590	27
MS333	366572	23~30	500	V-belt	7.2	152 (A-2)	800~1050	2.6 Hp	Chrome	3	V-Belt	399	243	279	27
MS417	354130	26~32	700	V-belt	11.5	152 (A-2)	900~1100	8-13 Hp	Chrome	3	V-Belt	415	242	363	27
MS657	354233	36~46	700	V-belt	21.7	229 (B-2)	650~850	6 Hp	Ceramic	3	V-Belt	510	312	419	27
MS757	354234	52~67	700	V-belt	23.8	229 (B-2)	750~950	7 Hp	Ceramic	3	V-Belt	551	312	419	27
MS600F	354067	36~60	726	V-belt	9.8		800~1250	8.5 Hp	Chrome	5	Shaft 20mm	370	218	145	31
MS1000F	354068	60~100	437	V-belt	10.0		800~1250	8.5 Hp	Chrome	5	Shaft 25mm	397	254	144	31
MS1300F	354069	82~128	580	V-belt	21.0		700~1050	14.5 Hp	Chrome	5	Shaft 25mm	467	338	200	31
MS1600F	354070	104~160	437	V-belt	22.0		700~1050	13.5 Hp	Chrome	5	Shaft 30mm	500	338	200	31
MSD41 3/4 Gas	366537	30	570	Direct	5.6	--	3600	5.5 Hp	Chrome	3	Direct	195	255	210	26
MSD41 5/8 Electric	366538	30	570	Direct	5.6	--	3600	3.5 Hp	Chrome	3	Direct	195	255	210	26
MSD51 3/4 Gas	366559	40	570	Direct	7.8	--	3600	6.5 Hp	Chrome	3	Direct	235	337	176	26

HOVER MOWER

Model	Part Number	Displacement	Carb/EPA Engine	Dry Weight	Fuel Tank Capacity	Start Assist	Fuel Cap Ret. Ring	Cutting Width	Cutter System	Cutting Height	Page
MHM480	845995	79.2cc	CER800	39 lb	71 oz	✓	✓	19 inch	3 blades	2.25"-2.75"	12



SPRAY PISTON PUMP ENGINE COMBO

Model	Part Number	Pump	Dry Weight (Kg)	Cylinder Coating	Engine	Suction Volume (Liter)	Max Pressure	Page
MS156EEA	358489	MS156	6.9	Chrome	Mitsubishi GB101LN	13	500 psi	28
MS331ECH	358585	MS330	36.0	Chrome	Honda GX160	24	500 psi	28
MS415ECH	358584	MS415	40	Ceramic	Honda GX161	30	700 psi	28
MSD41TEC	366541	MSD41	30.0	Chrome	Honda GX160	30.3	570 psi	28
MSD41TEC-H	366545	MSD41	32.5	Chrome	Honda GX160	30.3	570 psi	28

SKID SPRAYERS

Model	Part Number	Chemical Tank (Liter)	Pump	Dry Weight (Kg)	Engine	Suction Volume (Liter)	Max Pressure	Spray Gun	Hose	Hose Reel	Length (cm)	Width (cm)	Height (cm)	Page
MSD41-50	849302	200	MSD41	217	Honda GX160	23.2	570 psi	MD9 gun	100 meter, 10mm	Manual	69	55	55	29
MSD41-50TE	849301	200	MSD41	158	Honda GX160	23.2	570 psi	MD9 gun	100 meter, 10mm	Electric	48	30	54	29
MSD41-100T	849304	400	MSD41	177	Honda GX160	23.2	570 psi	MD9 gun	100 meter, 10mm	Manual	48	30	54	29
MSD41-100TE	849305	400	MSD41	195	Honda GX160	23.2	570 psi	MD9 gun	100 meter, 10mm	Electric	48	30	54	29
MSD41-100	849308	400	MSD41	223	Honda GX160	23.2	570 psi	MD9 gun	100 meter, 10mm	Manual	69	55	64	29
MSD41-100E	849309	400	MSD41	241	Honda GX160	23.2	570 psi	MD9 gun	100 meter, 10mm	Electric	69	55	54	29
MSD41-200	849306	760	MSD41	240	Honda GX160	23.2	570 psi	MD9 gun	100 meter, 10mm	Manual	69	55	29	29
MSD41-200E	849307	760	MSD41	259	Honda GX160	23.2	570 psi	MD9 gun	100 meter, 10mm	Electric	69	55	55	29

TRACTOR BOOM SPRAYER

Model	Part Number	Required (Hp)	Dry weight (Kg)	Engine	Chemical tank Capacity (Liter)	Boom length (meter)	Flow rate (L/min)	Nozzle type	Nozzle Holder	Piston pump	Page
BSM201-3MX	328290	14-24	110	Tractor PTO	200	4.2	21.4-30	14	(2-way)	MS331	30
BSM-301	720032	30	125	Tractor PTO	300	7.8	23.4	25	(2-way)	MS331	30
BSM-500F-1	328244	34	200	Tractor PTO	500	10.2	53	34	(2-way)	MS655	30

AIR BLAST SPRAYER

Model	Part Number	Required (Hp)	Dry Weight	Engine	Chemical tank Capacity (Liter)	Air velocity (m/seg)	Flow rate (L/min)	Nozzle Type	Nozzle Holder	Piston pump	Page
SSD600	366906	14-24	350	Tractor PTO	600	27~28	46	14	(2-way)	MS800	31

HI-CLEARANCE BOOM SPRAYER

Model	Part Number	Chemical tank Capacity	Dry Weight	Engine	Engine Hp	Ground Clearance (cm)	Distance between tires	4WD / 4 WS	HST	Oil Hydraulic System	Boom length	Boom spray height (cm)	Nozzle type	Nozzle Holder	Piston Pump	Flow Rate	Page
BSA500	720266	500 L	800	Kubota D722 (Diesel)	14.5	81	1500 mm	√	√	√	7.8 meter	33 to 153	26 nozzles	(2-way)	MS620S	60	32
BSA500	720419	500 L	820	Kubota D722 (Diesel)	14.5	81	1800 mm	√	√	√	7.8 meter	33 to 153	26 nozzles	(2-way)	MS620S	60	32
BSA500	720217	500 L	840	Kubota D722 (Diesel)	14.5	81	2000 mm	√	√	√	7.8 meter	33 to 153	26 nozzles	(2-way)	MS620S	60	32
BSA-500JMQ	720238	500 L	895	Kubota D722 (Diesel)	14.5	110	1800 mm	√	√	√	10.2 meter	33 to 153	33 nozzle	(2-way)	MS620S	60	33
BSA950.LA, 1800mm	720233	950 L	1170	Kubota D1105 (Diesel)	20.9	81	1800 mm	√	√	√	Telescopic 9.9 to 15.9 meter	33 to 153	53 nozzle	(2-way)	MS1000	100	33
BSA950.CE, 1800mm	721208	950 L	1365	Kubota D1105 (Diesel)	20.9	81	1800 mm	√	√	√	Telescopic 9.9 to 15.9 meter	33 to 153	53 nozzle	(2-way)	MS1300	130	33





MARUYAMA®

INTERNATIONAL
PRODUCT CATALOG



**MORE
POWER
FOR THE PROS!**

Contact Your Local Maruyama Distributor

