

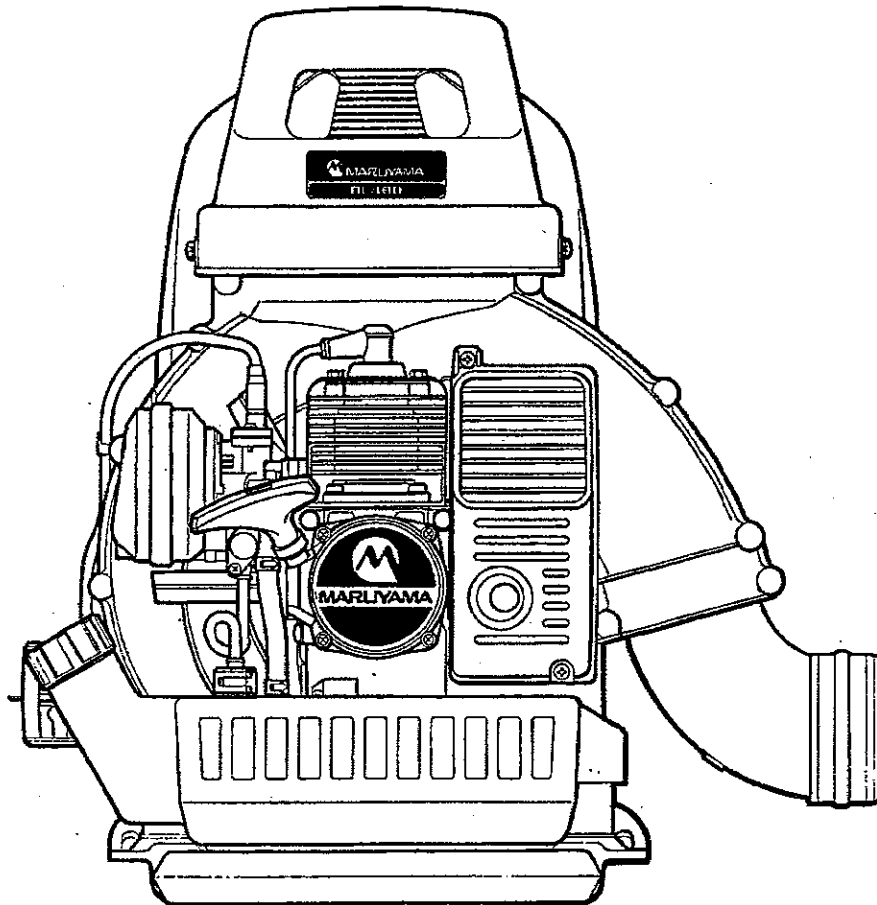



INSTRUCTION MANUAL

FOR BACKPACK POWER BLOWER

MODEL: BL400/BL480



It is essential that any operator of a MARUYAMA Backpack Power Blower reads and understands the contents of this manual before the engine is started.

Important safety instructions will be identified by the safety symbol. 

Failure to comply with the instructions in this manual may result in serious injury.

FOREWORD

This Instruction Manual is designed to familiarize the operator with the various features and component parts of the equipment and to assist you with the assembly, operation and maintenance of your new Power Blower. Please read this Instruction Manual carefully before using the blower, and acquaint yourself thoroughly with the equipment.

Special attention should be given to the Safety Instructions provided throughout the Instruction Manual.

For additional assistance, contact any local authorized Maruyama dealer, or Maruyama U.S., Inc., 301 - 30th St. NE, Suite 118, Auburn, WA 98002.

TABLE OF CONTENTS

	Page		Page
Foreword.....	1	Storage.....	7
Specifications.....	1	Regular Maintenance.....	8
Safety Instructions.....	2	*Air Filter.....	8
Assembly Instructions.....	3	*Spark Plug.....	8
Before Operation.....	4	*Fuel Filter.....	9
Operating Instruction.....	5	*Cooling Fins.....	9
*Throttle Control Lever.....	5	*Muffler And Exhaust Ports.....	10
*Starting Procedure.....	6	*General Cleaning Tightening.....	10
*Blower Operation.....	7	Warranty.....	BACK COVER
*Stopping The Engine.....	7		

SPECIFICATIONS

Model	BL400	BL480
Dimensions L X W X H	14.2 X 18.7 X 20.3 in. (360 X 475 X 515mm)	15.0 X 18.3 X 20.9 in. (380 X 465 X 530mm)
Dry Weight	19.0 lbs(8.6kg)	19.8 lbs(9kg)
Engine Type	KAWASAKI/2-Stroke, Air cooled	
	TE40	TE48
Displacement	40.2cc	48.6cc
Ignition Type	Electric	
Carburetor	Pulse pump	
Fuel Tank Capacity	1.3qts(1.2 lit)	2.1qts(2.0 lit)
Attachments (Standard)	Four Section Pipe, W/Fan-blower Head	



SAFETY INSTRUCTIONS



1. Read and understand this Instruction Manual before using the power blower. Be thoroughly familiar with the proper use of the power blower.
2. Never allow children to operate the power blower. It is not a toy. Never allow adults to operate the unit without first reading the Instruction Manual.
3. Become familiar with the controls and know how to stop the engine quickly.
4. Always use eye protection and hearing protection.
5. Keep the area of operation clear of all persons, particularly small children and pets.
6. Never operate a power blower when you are fatigued.
7. Never operate a power blower without proper guards or other protective safety devices in place.
8. Dress properly; do not wear loose clothing or jewelry that can be caught in moving parts. Always wear substantial footwear, long pants, and long sleeved shirt.
9. Gasoline is highly flammable; handle it carefully.
 - A. Do not smoke while handling gasoline.
 - B. Use an approved fuel container for storing the gasoline/oil mixture.
 - C. Do not fill the fuel tank when the engine is hot or running.
 - D. Fill the fuel tank outdoors and only up to one-half inch from the top of the tank. Do not fill the filler neck.
 - E. Wipe away any spilled gasoline before starting the engine.
10. Always be sure of your footing; keep a firm hold of the blower pipes, and walk, never run while operating a power blower.
11. Use the correct accessories. Do not use the power blower for any job except that for which it is intended.
12. Keep all fasteners tight and be sure the power blower is in safe working condition. Follow the maintenance instructions provided on page 8-10 of this manual.
13. Do not put hands or feet near or under the rotating parts. Keep clear at all times.
14. If the power blower should start to vibrate abnormally, stop the engine immediately and check for the cause. Vibration is generally a warning of trouble.
15. Avoid using the power blower near rocks, gravel, stones and similar matter in order to avoid dangerous flying debris.
16. Use the power blower only in daylight or good artificial light.

The MARUYAMA BACKPACK POWER BLOWER comes with an Instruction Manual and a Warranty Registration Card. Assembly and attachment of the throttle lever bracket and blower pipes are required.

ASSEMBLY INSTRUCTIONS

STEP #1) Locate and identify all the components(see sketch).

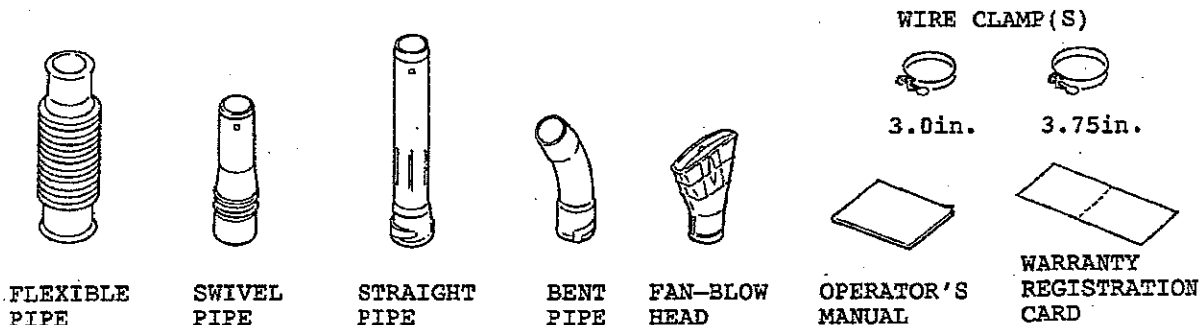

STEP #2) Using the WIRE CLAMPS, connect the FLEXIBLE PIPE to the blower, and the SWIVEL PIPE to the flexible pipe (see sketch below).

STEP #3) Assemble the STRAIGHT PIPE, BENT PIPE, and FAN-BLOW HEAD, then connect them to the swivel pipe(see sketch below).

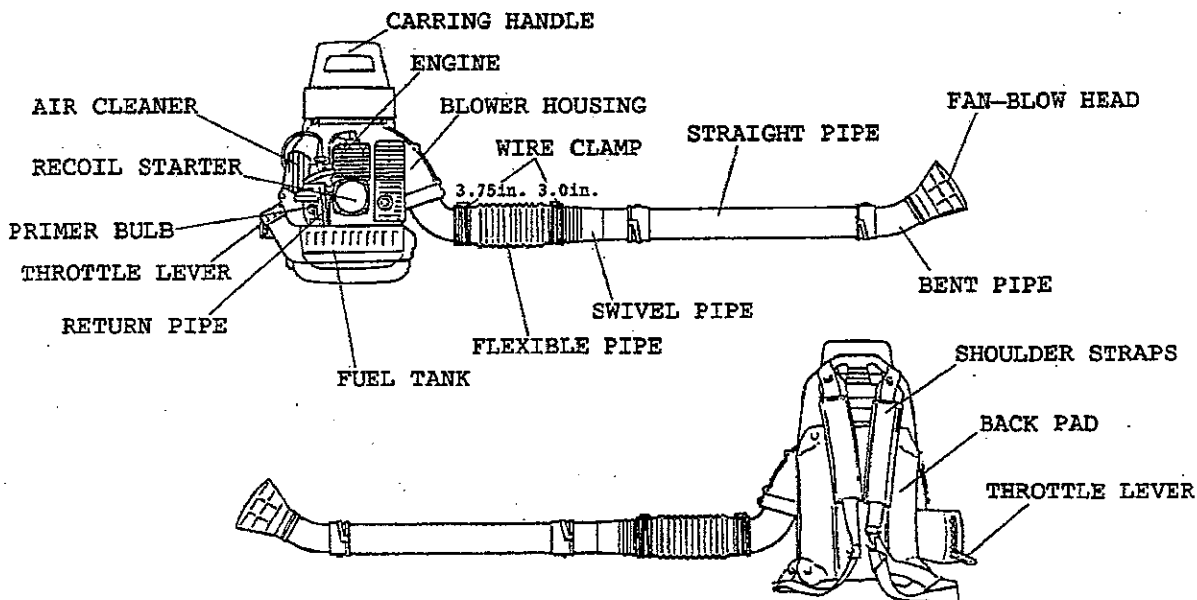

BEFORE OPERATION

Be sure the power blower is correctly assembled and all fasteners and fittings are properly secured.

FUEL: MIXING GASOLINE AND OIL



CAUTION—READ THE SAFETY INSTRUCTION CONCERNING GASOLINE ON PAGE(2).

The two-cycle engine used on the MARUYAMA power blower requires a mixture of GASOLINE and OIL for lubrication of bearings and other moving parts. The correct fuel mixture ratio is 25:1, which is 5.0oz. of oil mixed with one gallon of gasoline.

NOTE: Gasoline and oil must be premixed in a clean gasoline container. Never mix gasoline and oil indoors or in the power blower fuel tank. Always use fresh gasoline.

Add a small amount of unleaded regular gasoline to a gasoline container. Pour the proper amount of two-cycle oil into the gasoline container. Do not use multi-viscosity oils. Install the cap on the gasoline container before shaking. Shake the gasoline container vigorously so the oil mixes with the gasoline. Add the additional gasoline needed to complete the required amount of mixed fuel (see the fuel mixture chart below).

IMPORTANT: Do not fill the blower fuel tank with gasoline that does not have oil mixed in it. Do not use gasoline additives because the engine could be damaged.



WARNING!! NEVER USE GASOHOL OR ALCOHOL BLENDED FUELS IN MARUYAMA ENGINES.

Before filling the power blower fuel tank, clean around the fuel tank cap so dirt and debris does not enter the fuel tank. Always shake the fuel container before filling the fuel tank. Remove the fuel cap, then fill the fuel tank to within 1/4-1/2 inch from the top of the tank. Avoid filling the fuel tank filler neck. Install the cap securely onto the fuel tank.

FUEL MIXTURE CHART FOR 25:1 RATIO

WITH	1 GALLON GASOLINE MIX	5.0 oz OIL
	2 GALLON GASOLINE MIX	10.0 oz OIL
	5 GALLON GASOLINE MIX	25.0 oz OIL

OPERATING INSTRUCTIONS

THROTTLE CONTROL LEVER

Locate and understand the operation of the throttle control lever. When the power blower is positioned on the back of the operator, the throttle control lever, is located on the left side of the operator.

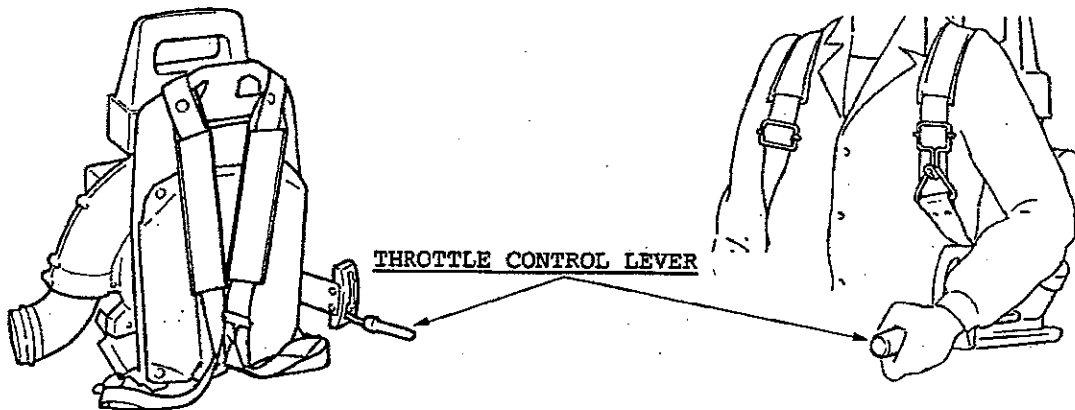

The lowest position of the lever is the "STOPPED" setting, and the highest position is the "FULL THROTTLE" setting (maximum R.P.M.).

BL400

The handle of the throttle control lever slides in or out for the convenience of the operator.

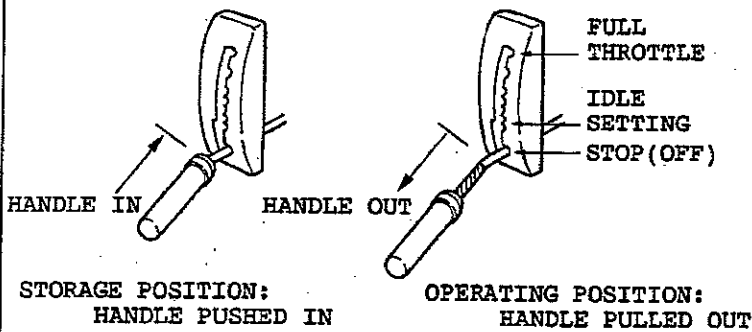

BL480

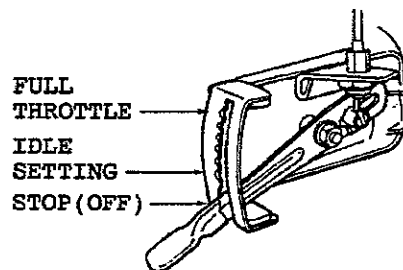

STARTING PROCEDURE

STEP #1) Pump the "PRIMER BULB" on top of the fuel tank until fuel can be seen flowing through the "FUEL-RETURN LINE".

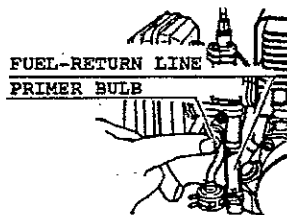

STEP #2) Move the "CHOKE LEVER" fully upward to the closed position. If the engine is already warm, only a partial or open (no choke) choke setting may be required.

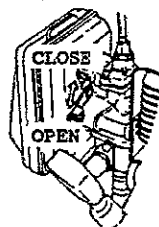

STEP #3) Set the throttle lever at 1/2 speed.

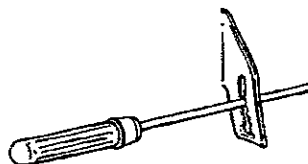

STEP #4) Pull the "STARTER GRIP" briskly to start the engine.

NOTE: Only short pulls are necessary. Never pull the starter cord to its fullest extension. Never let go of the starter grip until it is at the fully returned position.

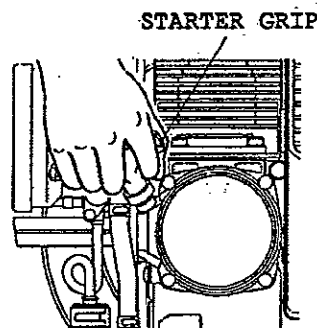

STEP #5) Warming up the engine. When the engine has started, slowly move the "CHOKE LEVER" fully downward to the open position. Allow the engine to "WARM-UP" at less than 1/2 speed.

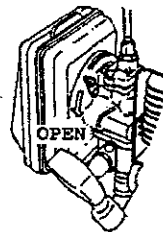

If a MARUYAMA engine fails to start after following the above procedures, contact an authorized MARUYAMA dealer.

BLOWER OPERATION

When the engine has warmed-up, the power blower can be positioned on the back of the operator. First slip the right arm through the right shoulder strap, then put the left arm through the left shoulder strap and connect the triangle-ring to the hook. (Note: For easier access, the triangle-ring/hook is a "Quick-Release" feature of the left shoulder strap. See sketch below).

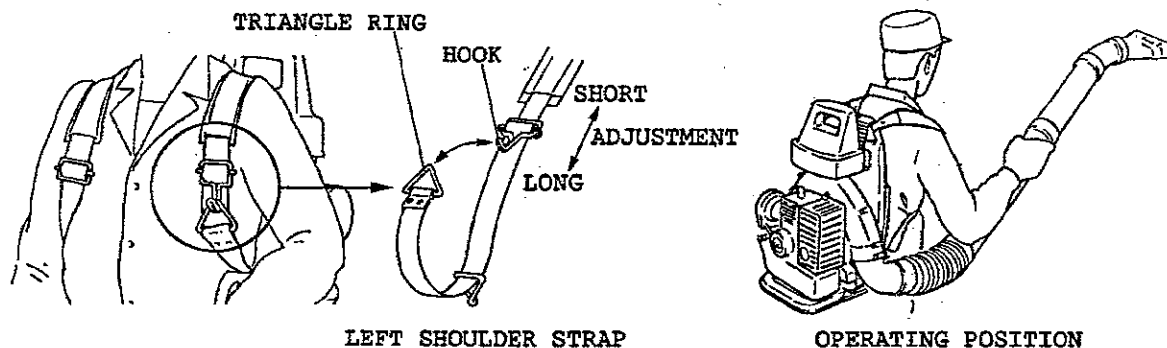

Both shoulder straps are adjustable to provide a comfortable fit for the operator. When the power blower is positioned and ready for operation, adjust the throttle to a speed required to accomplish the task.

STOPPING THE ENGINE

Always run the engine at idle speed for a few minutes to allow cooling before stopping. To stop the engine, move the throttle control lever all the way downward to the "STOP" position.

STORAGE

For long-term storage of the power blower, first perform all regular maintenance procedures and needed repairs. Empty the fuel tank. Disconnect the fuel-return line from the carburetor, then gently hold the tickler lever down while pumping the primer bulb until fuel stops discharging from the fuel-return fitting. Start the engine and allow it to run until it stops. Pull the starter cord a few times to remove any excess fuel from the engine. Remove the spark plug and insert a small amount of oil into the cylinder. Slowly pull the starter cord and bring the piston to a position closest to the spark plug hole. Re-install the spark plug. Apply a thin coating of oil to all the metal surfaces and store the power blower in a dry place.

REGULAR MAINTENANCE

Before each use, the power blower should be inspected for proper assembly and fitness of all components. All fasteners should be checked for correct tightness. Always inspect for fuel leaks.



CAUTION—Do not attempt to start or operate a power blower that indicates a fuel leak.

AIR FILTER

The air filter should be inspected each time the power blower is used (or more often with extreme conditions). To inspect, remove the air filter cap. The element is easily pulled from the case.

Clean the element by washing it in kerosene or warm detergent solution. Squeeze it dry. Apply #30wt. oil to the element, removing all excess oil, and install the element.

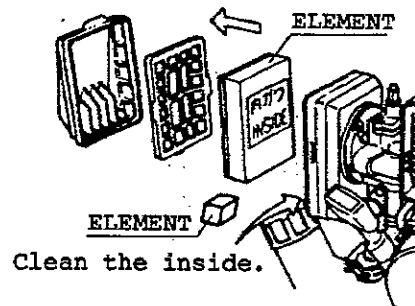

SPARK PLUG

The spark plug should be removed from the engine and checked after each fifty (50) hours of use. The tips can be cleaned with a stiff brush. Adjust the gap to 0.024–0.028 inches (see sketch). Replace the spark plug if it is oil-fouled or damaged.

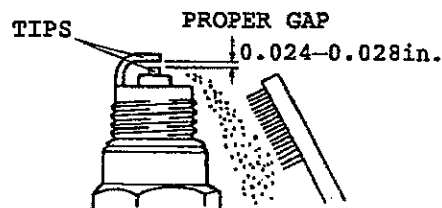

CAUTION—The correct torque for the spark plug is 10–12 ft.lbs. Do not over-tighten.

FUEL FILTER

The fuel filter should be cleaned and inspected for damage after each fifty (50) hours of use. The fuel filter is attached to the fuel pickup tube inside the fuel tank. Loosen the clamp and take out the fuel filter.

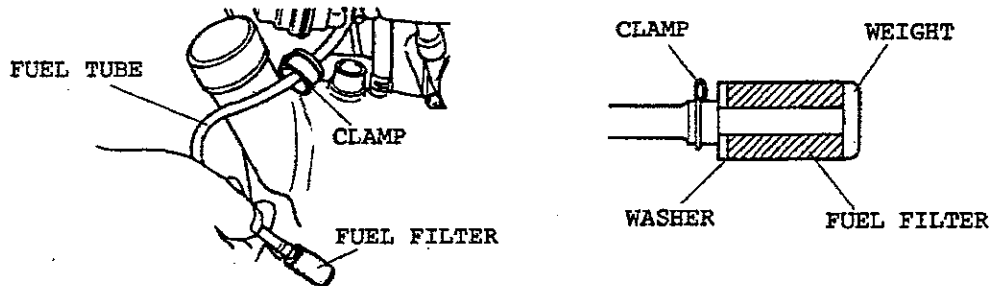

To clean the fuel filter, remove it from the fuel tube and wash it with fuel mixture. Inspect and clean the fuel tank before re-installing the fuel filter. Always replace a defective fuel filter.

COOLING FINS

Free passage of air through the cylinder cooling fins is required to prevent poor engine performance and shortened engine life. Regularly check and clean all debris from the cooling fins by removing the engine cover (see sketch).

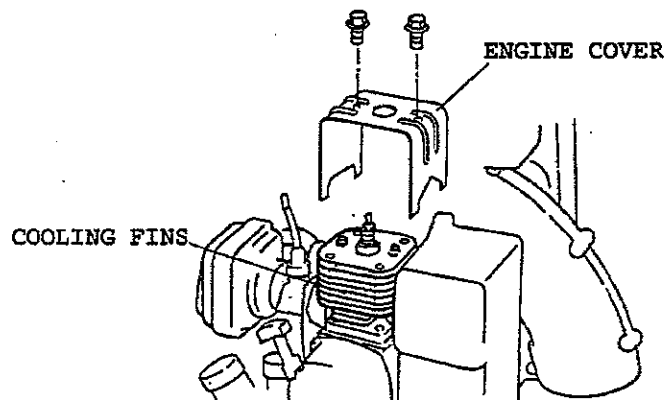

MUFFLER AND EXHAUST PORTS

The muffler should be removed and serviced after each one hundred (100) hours of use. At the same time, the exhaust ports should be cleaned and inspected. An AUTHORIZED MARUYAMA DEALER should be contacted for this service.

GENERAL CLEANING AND TIGHTENING

The MARUYAMA power blower will provide maximum performance for many, many hours if it is maintained properly. Good maintenance includes regular checking of all fasteners for correct tightness, and cleaning the entire machine. Contact an authorized MARUYAMA dealer for additional maintenance suggestions.



LIMITED WARRANTY STATEMENT

All Maruyama products are warranted to the original purchaser to be free from defects in material and workmanship for a period of two (2) years from the date of purchase when applied to residential use, or six (6) months from the date of purchase when applied to commercial use.

Any part(s) of Maruyama products found to be defective within the warranty period shall, at Maruyama's option, be repaired or replaced without charge. Warranty consideration is obtained by delivering any Maruyama product believed to be defective to an Authorized Maruyama Service Dealer within the applicable warranty period.

Warranty will not apply to conditions resulting from:

1. Damage(s) and/or costs associated with shipping and/or transportation.
2. Lack of normal maintenance, adjustments, or service required for regular use of the product.
3. Modifications, service/repairs, parts or components not authorized by Maruyama.
4. Normal wear, accident, abuse, neglect, misuse, negligence, improper fuels/fuel mixtures, or failure to operate or maintain the product in accordance with instructions approved by Maruyama.

Maruyama shall not be liable for any special, consequential, direct or indirect damages, and expressly states there are no implied warranties. Some states do not allow limitation of incidental or consequential damages, accordingly the above limitations and exclusions may not apply to you.

This warranty provides you with specific legal rights which may vary from state to state.

It is the owners responsibility to properly complete and mail the Warranty Registration Card. Proof of purchase and registration will be required in order to obtain warranty service.

For the name of the authorized Maruyama dealer nearest you.

CONTACT

Maruyama U.S., Inc. / 301 - 30th Street NE, Suite 118 / Auburn, WA 98002